

Rocking Piston

Compressors and Vacuum Pumps

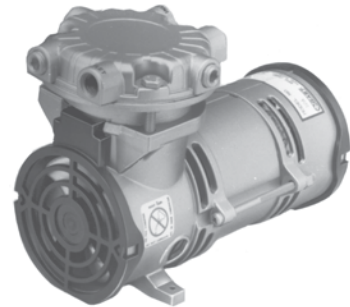

The Gast Group Difference

For over 90 years, Gast Manufacturing has been providing innovative air solutions to a broad breadth of customers. With the relatively recent addition of JUN-AIR, we have expanded our capabilities and formed, “The Gast Group.” Together, our diverse engineering background and pneumatic experience allow us to provide both component and system solutions to meet all of your pneumatic needs...all backed by our strong commitment to quality and customer support.

Products for Almost Any Application – Worldwide

We offer an extensive and versatile line of air-moving products, including vacuum pumps, compressors, air motors, gearmotors, vacuum generators, and regenerative blowers. We design and build these components for original equipment manufacturers worldwide, but we also develop complete pneumatic solutions to solve tough customer challenges.

To ensure fast, efficient delivery of products, Gast has a vast network of sales representatives/distributors throughout the United States and the world. Plus, we maintain direct sales and service facilities in Europe, Hong Kong, and Shanghai, China.

Unparalleled Design Expertise

Unlike other manufacturers, who might expect you to modify your pneumatic system to fit their available product(s), Gast is committed to finding the right product to meet your specific needs. If we don't have a high-quality, off-the-shelf product to fit your existing application or meet your anticipated needs, we'll propose customized cost-effective design options that will serve your special requirements. We can even develop and produce your complete pneumatic system for you.

Our experienced Research and Development engineers and Product engineers work together to analyze customer needs and use computer-aided design to generate timely solutions for air-handling problems. The design team has one goal: to create problem-solving solutions that capitalize on the latest available technology, meet all application requirements, and benefit from cost-effective production methods. The end result: products and solutions that are the best value in the marketplace for our customers.

A Lasting Commitment to Quality

We invest heavily in both equipment and people to maintain the consistent quality for which our products are known worldwide, and we have done so since day one. As early as 1983, we implemented a total quality process designed to ensure the quality of our products. In keeping with that tradition, Gast has achieved ISO 9001 certification, making us a member of the elite group of manufacturing companies in the world to receive that certification.

European Community Directives

With extensive sales outside the United States, Gast has pledged to conform to the European Community Directives. These directives contain essential requirements concerning health, safety, environment, and consumer protection for all products targeted for the European Community market. Currently, all Gast products available for sale in the European Community are in compliance with the Machinery, Low Voltage, and Electromagnetic Compatibility Directives.

Pictorial and dimensional data is subject to change without notice. The information presented is based on technical data and test results of nominal units. It is believed to be accurate and is offered as an aid in the selection of Gast products. It is the user's responsibility to determine suitability of the product for intended use and the user assumes all risk and liability whatsoever in connection therewith. Environmental and application conditions may affect advertised life.

Why use a Rocking Piston Product?

Variety

Gast oilless Rocking Piston air compressors and vacuum pumps, available in single, twin, miniature, and tank-mounted styles, are the perfect choice for hundreds of applications. Choose from dual frequency, shaded pole, and permanent split capacitor (psc) electric motors with AC multi-voltage motors to match North American, European, and worldwide power supplies. A complete line of recommended accessories as well as 6, 12, and 24 volt DC models in brush and brushless types are also available.

Performance

The rocking piston combines the best characteristics of piston and diaphragm air compressors into a small unit with exceptional performance. Air flow capabilities from 3.4 LPM to 5.5 CFM (9.35 m³/h), pressure to 175 psi (12.0 bar) and vacuum capabilities up to 29 inHg (31 mbar). Horsepowers range from 1/20 to 1/2 HP (0.04 to 0.37 kW).

Reliable

These pumps are made to stand up through years of use. The piston rod and bearing assembly are bonded together, not clamped; they will not slip, loosen, or misalign to cause trouble.

Clean Air

Because Gast ROC-R pumps are oil-free, they are ideal for use in applications in laboratories, hospitals, and the food industry where oil mist contamination is undesirable.

How Does a Rocking Piston Pump Work?

In a reciprocating motion, a flexible cup mounted on top of the connecting rod creates vacuum or pressure as the cup maintains a seal against the cylinder walls in a rocking motion.

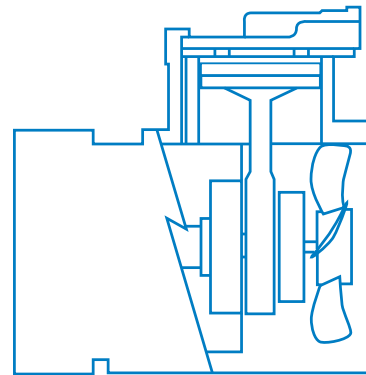

Gast Compressors and Vacuum Pumps Performance*

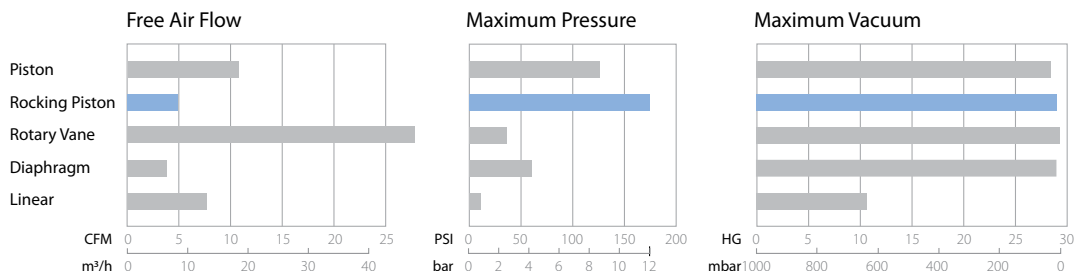

*Shown here are performance ranges of our positive displacement models. Performance shown on inside charts is for continuous operation. Higher performance is possible on an intermittent basis (10 min. on/10 min. off) for some of the models listed. Consult Factory.

Rocking Piston Performance Overview

MODEL/ SERIES	MOTOR TYPE	POWER RATING		FREE AIR FLOW				MAXIMUM PRESSURE		MAXIMUM VACUUM	
		60 Hz		CFM		m ³ /h		psi	bar	inHg	mbar
		hp	kW	50 Hz	60 Hz	50 Hz	60 Hz				
8R (DC)		—	—	3.4 LPM		3.4 LPM		22.5	1.55	17	438
20R (AC)		1/30	0.025	12 LPM	14.7 LPM	12 LPM	14.7 LPM	35	2.41	21	302
30R (DC)		1/10	0.08	0.61		1.04		120	8.28	—	—
34R (DC)		1/4	0.19	0.80		1.36		200	13.8	—	—
55R	PSC	1/20	0.04	0.16	0.20	0.27	0.34	30	2.1	24	200
55R (DC)		1/10	0.07	0.25		0.42		30	2.1	24	200
LOA	ShP	1/16	0.05	—	0.38	—	0.65	90	6.2	25	167
LOA	PSC	1/6	0.12	0.52	0.83	0.88	1.41	100	6.9	26	133
LOA (DC)		1/10	0.07	0.62		1.05		100	6.9	27	99
LAA		1/6	0.12	1.28	1.52	2.17	2.58	60	4.1	29	31
SAA (STAGED)		1/6	0.12	—	1.75	—	3.00	—	—	29.5	15
SAA (PARALLEL)		1/6	0.12	—	3.00	—	5.10	—	—	27	99
SAA		1/6	0.12	—	1.95	—	3.31	30	2.1	—	—
ROA	ShP	1/8	0.09	1.05	1.25	1.87	2.12	100	6.9	26	133
ROA	PSC	1/4	0.19	1.50	1.60	2.55	2.72	100	6.9	27	99
ROA (DC)		1/8	0.09	1.50		2.55		—	—	26	133
RAA		1/4	0.19	2.5	2.7	4.25	4.59	100	6.9	27.5	82
71R (SINGLE CYL)		1/3	0.25	2.4	2.0	4.08	3.40	100	6.9	—	—
71R (TWIN CYL)		1/3 - 3/4	0.25 - 0.56	3.25 - 4.5	4.0 - 4.5	5.52 - 7.65	6.80 - 7.65	15 - 100	1.04 - 7.0	28	65
71R (TWIN CYL HIGH PRESSURE)		1/3 - 1/2	0.25 - 0.37	1.7	1.9	2.89	3.23	175	12.1	—	—
72R (SINGLE CYL)		1/3	0.25	2.0 - 2.5	2.5	3.4 - 4.25	4.25	100	7.0	28	65
72R (TWIN CYL)		1/3 - 3/4	0.25 - 0.56	2.5 - 5.5	2.5 - 5.5	4.25 - 9.35	4.25 - 9.35	25 - 100	1.73 - 7.0	29	31
74R		1/4	0.19	1.30	1.50	2.21	2.55	100	7.0	—	—
75R (SINGLE CYL)		1/4	0.25	1.9	1.9	3.23	3.23	—	—	27	99
75R (TWIN CYL)		1/3	0.25	4.5	5.1	7.65	8.67	40	2.8	27	99
81R		1/3	0.25	3.0	3.7	5.1	6.3	100	7.0	—	—
82R		1/3	0.25	4.4	4.9	7.1	7.6	100	7.0	—	—
82R (BLDC)		1/3	0.25	3.8		6.5		30	2.1	26	133

PSC - Permanent Split Capacitor

ShP - Shaded Pole motor

Catalog Performance Specifications

The specifications listed are that of a unit at sea level with an ambient temperature of 70°F (21°C), operating with normal electrical current conditions. The figures stated in this catalog are nominal approximations for models without accessories. Intake filters and exhaust mufflers, and the accumulation of contaminants in them during operation, will decrease the flow of air as well as the achievable pressure.

The units that we list in this catalog are a small portion of what we actually make. Those listed are considered “standard units” and are normally available from stock in small quantities. Variations are produced for many customers and by passing on to us the application specifications we might find an existing unit that fits your requirement. If we don’t and the quantity is sufficient, we will design a “special unit” for the application.

Pictorial and dimensional data is subject to change without notice.

The information presented in this catalog is based on technical data and test results of nominal units. It is believed to be accurate and is offered as an aid in the selection of Gast products. It is the user’s responsibility to determine suitability of the product for intended use and the user assumes all risk and liability whatsoever in connection therewith.

Typical Applications



Medical Applications

- Oxygen concentrators
- Eye surgery equipment
- Ventilation equipment
- Surgical aspiration equipment



Dental Applications

- Dental vacuum ovens
- Dental compressors
- Portable dental equipment



Laboratory Applications

- Lab test equipment
- Body fluid analysis
- Vacuum filtering
- Vacuum centrifuge



Other Applications

- Vacuum food sealer
- Tire inflation equipment
- Automotive suspensions
- Auto detailing equipment
- Refrigerants reclamation
- Dry sprinkler system
- Beverage dispensing
- Cable pressurization
- Vacuum frames
- Core drilling
- Paper counting machines
- Vacuum mixing
- Handicapped accessible doors
- Diving air





DC Motor

22.5 psi max. pressure
(1.55 bar)
17 inHg max. vacuum
3.4 LPM open flow

Optional cover shown on unit

Product Dimensions (inches, mm)

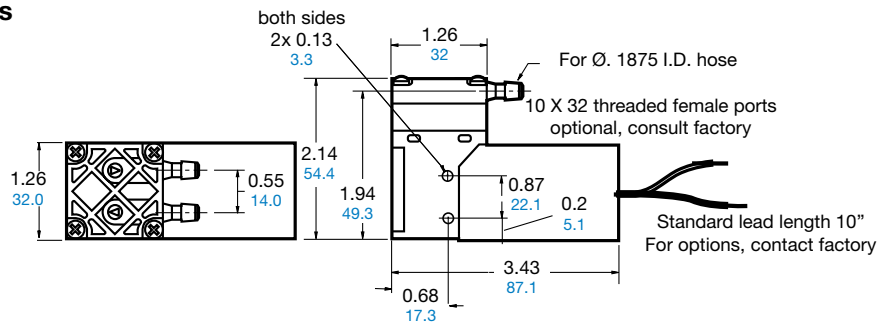

Product Specifications

Model Number	Motor Type	Amp. Draw	Valve Material	Net Weight	
				lb	kg
8R1110-201-1049	12V DC	0.60	@Neoprene	0.5	0.23
8R1110-201-1048	24V DC	0.30	@Neoprene	0.5	0.23
8R1110-101-1050	6V DC	1.10	* @EPDM	0.5	0.23
8R1110-101-1049	12V DC	0.60	* @EPDM	0.5	0.23
8R1110-101-1048	24V DC	0.30	* @EPDM	0.5	0.23

- Use as compressor or vacuum pump (same model)
- Maintenance-free ball bearings are sized for long life
- Cup and valve are easily field serviceable, if required
- Alternate stroke options available
- Custom mounting configurations available
- Head mounts in any of four positions
- Heads available with threaded or barbed ports
- Motor equipped with Electromagnetic Interference (EMI) Suppression
- Head assembly of chemical and heat resistant PPS for corrosion resistance
- EPDM (Ethylene Propylene Diene Monomer) valve and Neoprene valves

Product Performance

Note: Performance data taken at nominal voltage

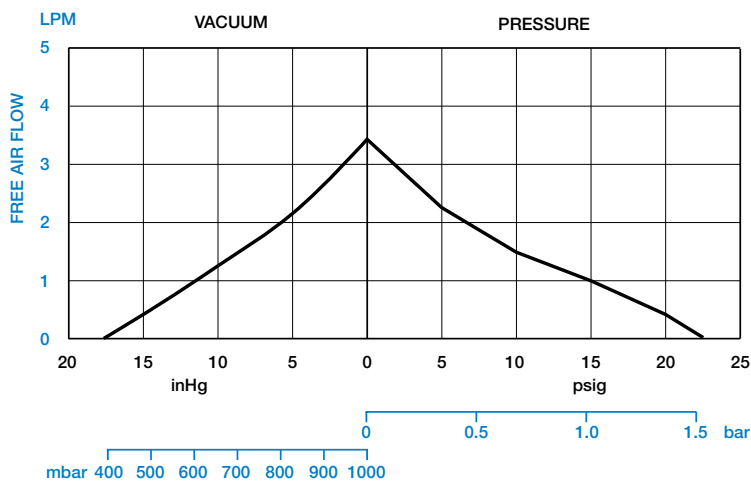



AC Motor

31 psi max. pressure (2.14 bar) 20.5 inHg max. vacuum
14.7 LPM open flow (20r125-101-c400asx, 60 Hz)

Product Dimensions (inches, mm)

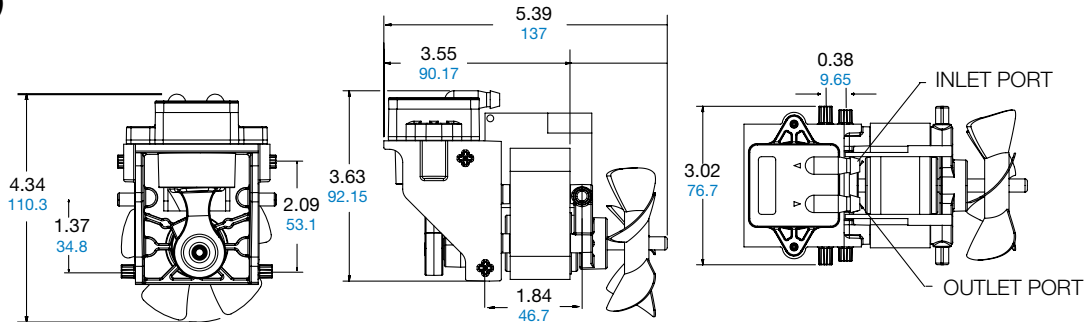

Product Specifications

Model Number	Motor Type	Amp. Draw	RPM	HP	KW	Net Weight lb	Net Weight kg
20R125-101-C400ASX	120-60 AC	1.5	3000	1/30	.025	2.40	1.09
20R125-101-C400CSX	230-50 AC	0.8	2500	1/30	.025	2.48	1.18

- Oilless operation
- Use as compressor or vacuum pump (same model)
- Excellent compressor life with full ball bearing construction
- Single shot thermal and current cutoff protection
- Alternate head mounting position available

Product Performance

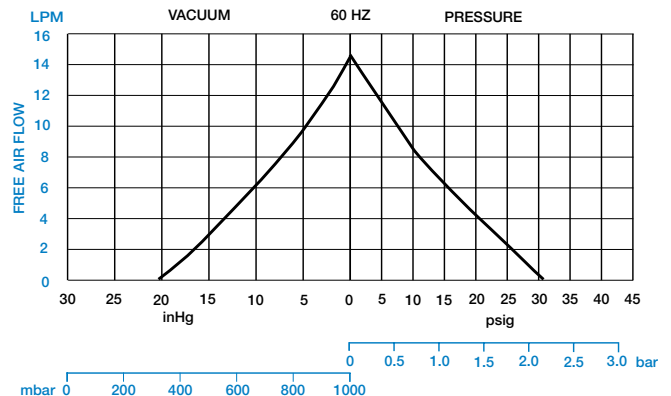
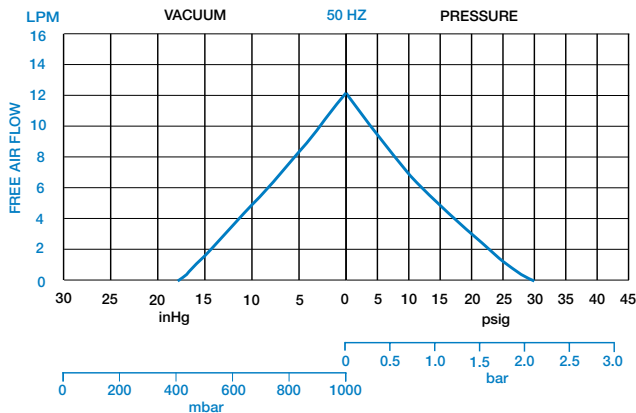



DC Motor

120 psi max. pressure, intermittent
0.61 CFM open flow

Product Dimensions (inches, mm)

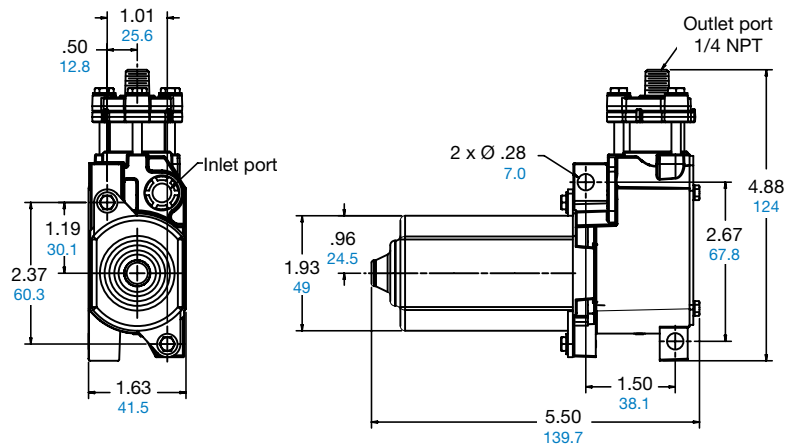

Product Specifications

Model Number	Motor Type	Amp. Draw	RPM	HP	KW	Net Weight	
						lb	kg
30R157-P101-L200	12V DC	8.0	3800	1/10	0.08	1.7	0.8

- Oilless operation
- 10% duty cycle (1 minute ON, 9 minutes OFF)
- Long-life cup material
- Custom specific mounting configurations available
- Custom exhaust port locations available

Product Performance

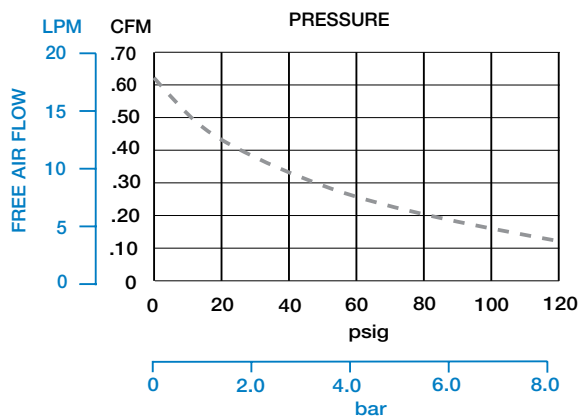

Duty cycle: At 120 psig, pump is rated for 10% duty (1.0 minute on, 9.0 minutes off)



DC Motor

200 psi max. pressure, intermittent
0.8 CFM open flow

Product Dimensions (inches, mm)

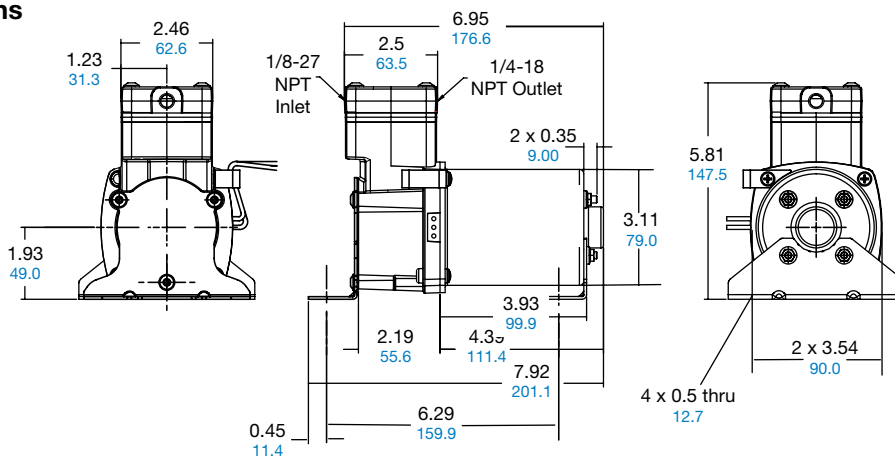

Product Specifications

Model Number	Motor Type	Amp. Draw	RPM	HP	KW	Net Weight lb	kg
34R156-P101-L100X	12V DC	13	2750	1/4	.0175	6.5	3.0
*34R156-P160-L100X	12V DC	13	2750	1/4	.0175	7.0	3.2

*Accessorized unit includes: braided hose with check valve, vibration isolators, and mounting hardware

- Oilless operation
- Motor mounted
- All wetted aluminum parts for corrosion resistance
- IP68 rating available
- Thermal overload protector
- 4-way reversible head
- Optional standard NPT inlet and exhaust port head
- VG2016 sintered bronze inlet silencer
- Robust intermittent duty cycle
- Bulk or individual pack available

Product Performance

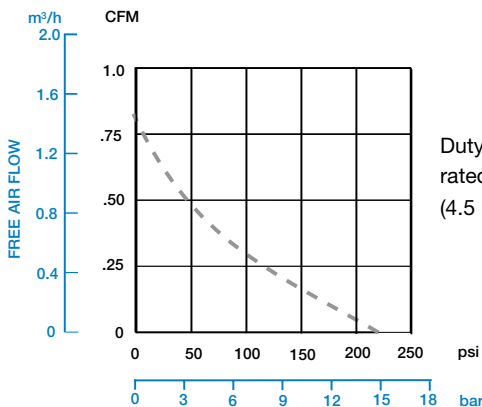

Duty cycle: At 150 psig, pump is rated for 30% duty (4.5 minutes on, 10.5 minutes off)



Brushless DC Motor

30 psi max. pressure continuous
(45 psi intermittent)
24 inHg max. vacuum
0.25 CFM open flow (each head)

PSC Motor

30 psi max. pressure continuous
(45 psi intermittent)
24 inHg max. vacuum
0.20 CFM open flow (each head)

Recommended Accessories

Repair kit part #K531
Vacuum gauge AA640
Vacuum relief valve AA204
Pressure gauge AA644B
Pressure relief valve AA203
Filter/muffler pressure VG2016
Filter/muffler vacuum AA922H

Product Dimensions (inches, mm)

AC MODELS

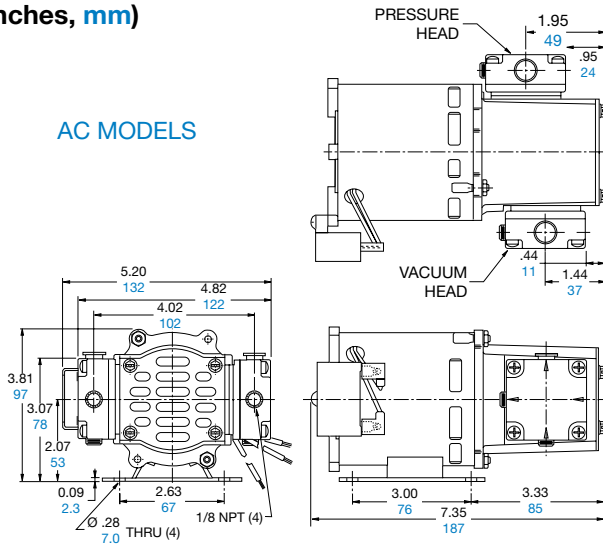

DC MODELS

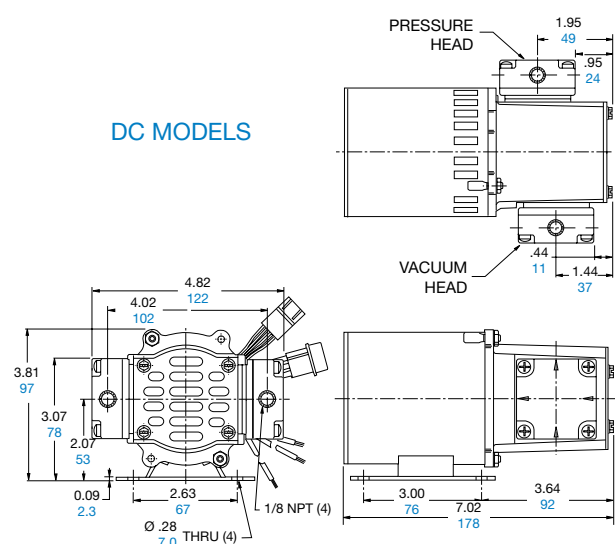

Product Specifications

Model Number	Motor	Motor Type	RPM	HP	KW	Net Weight lb	Net Weight kg
55R720-101-TKP	24V	BrushlessDC	1900*	10	0.07	5.0	2.25
55R720-101-STP	100-110/100-115V, 50/60-1	PSC (4 Pole)	1575 1275	0.054	0.04	5.0	2.25

*Speed can be varied by customer supplied electronics
Note: These units can be configured for either staged vacuum or parallel pressure operation.
Staged vacuum units capable of 27.5 inHg maximum vacuum.
Parallel pressure units capable of 20 psi continuous duty (approx. twice the flow shown in graphs)

- Pressure/vacuum simultaneously in a very small package
- Very low noise levels approx. 55 dB(a)
- All wetted aluminum parts treated for corrosion protection from moisture
- Very low power consumption (approx. 75 watts - AC version, 50 watts - DC version)
- Long life/non-service life (up to 12,000 hours depending on application)

Product Performance

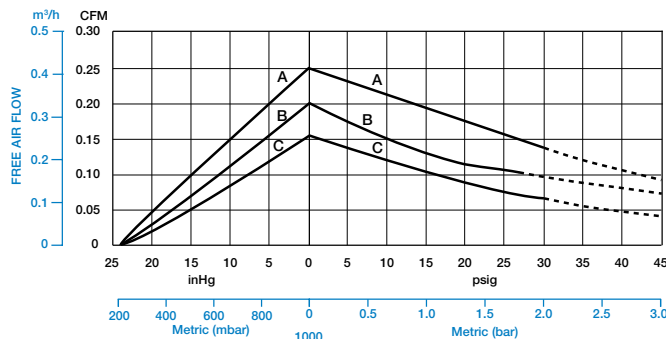

- A: 24V DC**
- B: 1575 RPM**
- C: 1275 RPM**

Pressure flow with one head running at max. vac.
Vacuum flow with one head running at 30 psi.

Dashed lines indicate intermittent duty



Shaded Pole Motor

90 psi max. pressure,
25 inHg max. vacuum
0.38 CFM open flow

PSC Motor

100 psi max. pressure
26 inHg max. vacuum
0.83 CFM open flow

DC Motor

100 psi max. pressure,
27 inHg max. vacuum
0.62 CFM open flow

Recommended Accessories

- Muffler/filters AH190
- Pressure gauge AF583
- Vacuum gauge AA640
- Pressure relief valve AF592S
- Vacuum relief valve AA207
- (3) Rubber feet AF584A
- Repair kit K476

Product Dimensions (inches, mm)

AC MODELS (capacitor shipped unattached)

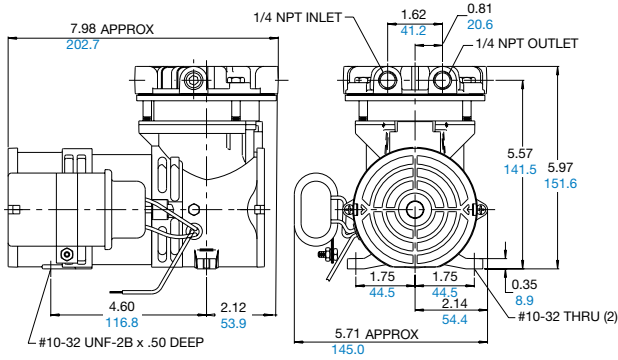

DC MODELS

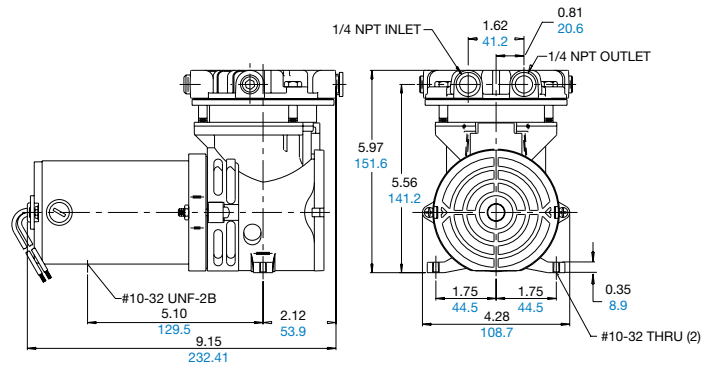

Product Specifications

Model Number	Motor	Motor Type	RPM		HP	KW	Net Weight	
			60 Hz	50 Hz			lb	kg
LOA-101-AA	115-60-1	Shaded pole	1575		1/16	0.05	6.6	3.0
LOA-101-HB	115/110-60/50-1	PSC	1575		1/16	0.05	8.6	3.9
LOA-101-HD	230/220-60/50-1	PSC	1575	1275	1/16	0.05	8.6	3.9
LOA-101-NL	100-50/60-1	PSC	1575	1275	1/8	0.09	7.6	3.5
LOA-P103-NL	100-50/60-1	PSC	1575	1275	1/6	0.12	7.6	3.5
LOA-P102-NQ	115-60-1	PSC	1575	1275	1/6	0.12	7.6	3.9
LOA-101-JR	11-15V DC		2000		1/10	0.07	6.6	3.0

- Oilless operation
- Motor mounted
- Rugged construction / low maintenance
- Low noise levels
- Capacitor AG331 (HB, HD motors) AF485A NL motor) AH364 (NQ motor) included

"P" models are pressure only

Product Performance

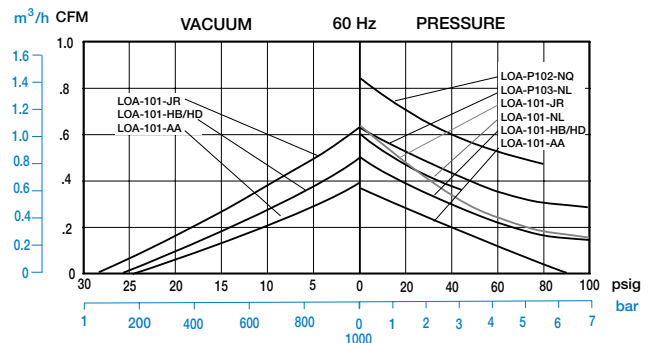
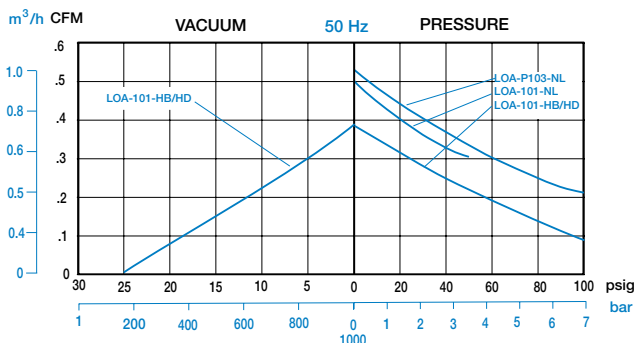



PSC Motor

60 psi max. pressure
29 inHg max. vacuum
1.5 CFM open flow

Recommended Accessories

- Muffler/filters AH190
- Pressure gauge AF583
- Vacuum gauge AA640
- Pressure relief valve AF592S
- Vacuum relief valve AA207A
- (4) Rubber feet AF584A
- Repair kits
 - K773 (LAA-101-NQ, LAA-V103-NQ)
 - K767 (LAA-V104-NQ)

Product Dimensions (inches, mm)

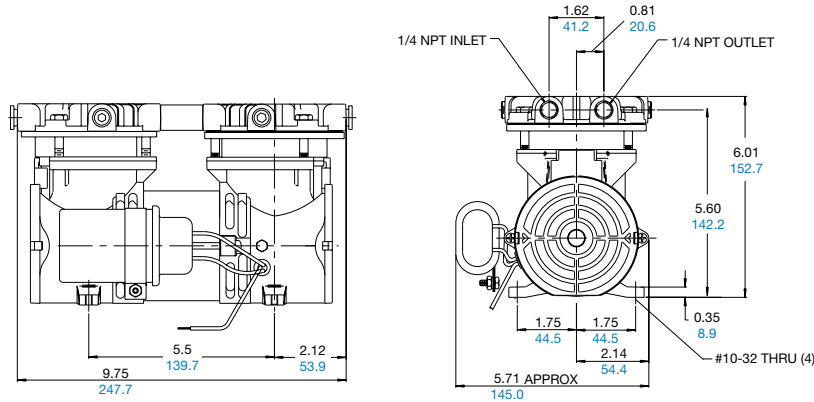

Product Specifications

Model Number	Motor	Motor Type	Staged/Parallel	RPM		HP	KW	Net Weight	
				60 Hz	50 Hz			lb	kg
LAA-101-NQ	100-60/50-1;115-60-1	PSC	Parallel	1575	1275	1/6	0.12	11.3	5.1
LAA-V103-NQ	100-60/50-1;115-60-1	PSC	Parallel	1575	1275	1/6	0.12	11.3	5.1
LAA-V104-NQ	100-60/50-1;115-60-1	PSC	Staged	1575	1275	1/6	0.12	11.3	5.1

- Oilless operation
- Motor mounted
- Rugged construction / low maintenance
- Low noise levels
- Capacitor AH364 included

"V" models are vacuum only

Product Performance

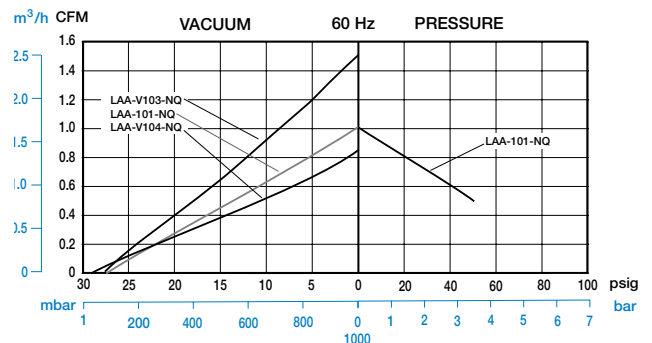
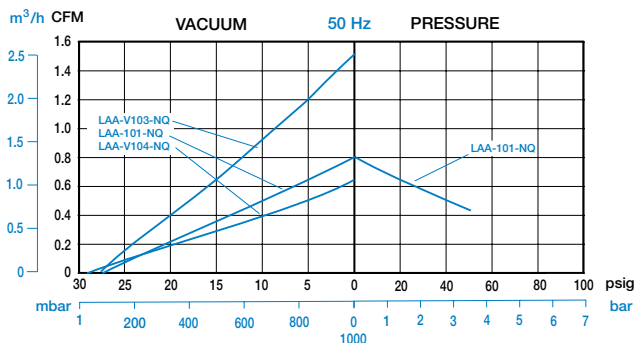



Standard units ship with grilles covering fans

PSC 4 Pole Motor
30 psi max. pressure,
29.5 inHg max. vacuum
3.0 CFM open flow

Recommended Accessories

- Mufflers/filters AH190
- Pressure gauge AF583
- Vacuum gauge AA640
- Pressure relief valve AA205
- Vacuum relief valve AA207
- (4) Rubber feet AF584A

Repair kit(s):

- SAA-P107-NQ, SAA-V108-NQ
- 1 each K756, K757
- SAA-V109-NQ
- 2 each K757

Product Dimensions (inches, mm)

SAA-P107-NQ

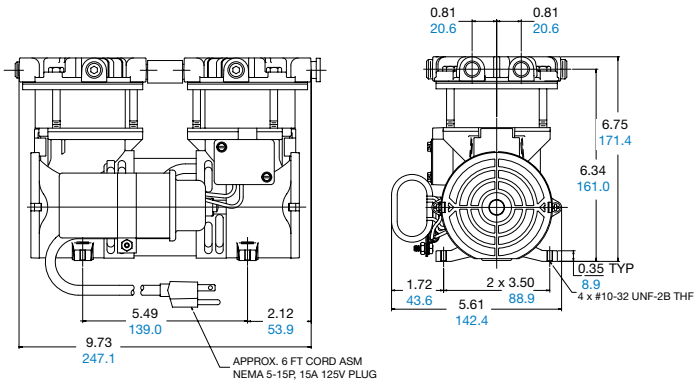

SAA-V108-NQ, SAA-V109-NQ

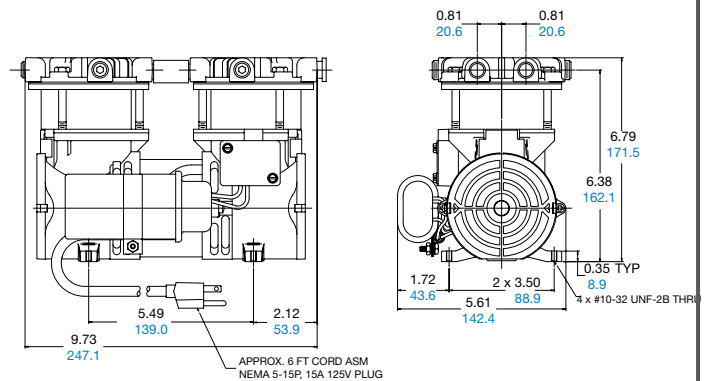

Product Specifications

Model Number	Motor	Motor Type	Parallel/Staged	RPM 60 Hz	HP	KW	Net Weight lb	Net Weight kg
SAA-P107-NQ	115-60-1	PSC	Parallel	1575	1/6	0.12	11.1	5.0
SAA-V108-NQ	115-60-1	PSC	Parallel	1575	1/6	0.12	11.1	5.0
SAA-V109-NQ	115-60-1	PSC	Staged	1575	1/6	0.12	11.1	5.0

- Oilless operation
- Motor mounted
- Rugged construction / low maintenance
- Low noise levels

"P" models are pressure only; "V" models are vacuum only

Product Performance

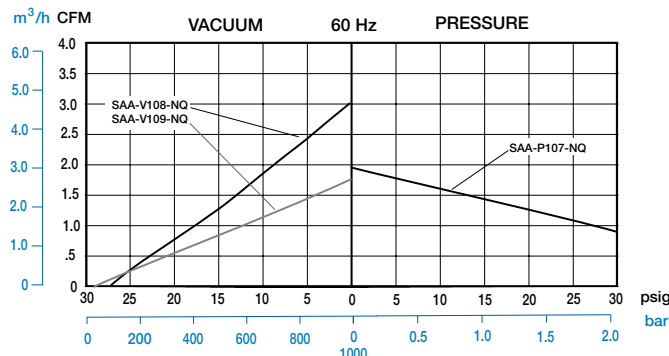



Shaded Pole Motor

100 psi max. pressure
26 inHg max. vacuum
1.6 CFM open flow

PSC 4 Pole Motor

100 psi max. pressure
27 inHg max. vacuum
.78 CFM open flow

DC Motor

100 psi max. pressure
26 inHg max. vacuum
1.1 CFM open flow

Recommended Accessories

Filter for vacuum only AA617G
Pressure gauge AF583
Vacuum gauge AA640
Pressure relief valve AF592S
Vacuum relief valve AA550C-V
(4) Rubber feet AF584A
Repair kit K757

Product Dimensions (inches, mm)

AC MODELS

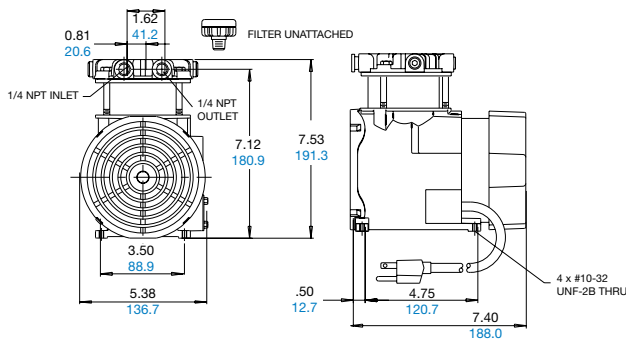

DC MODELS

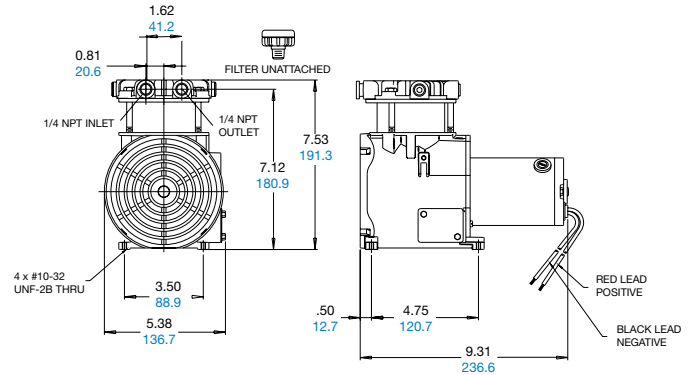

Product Specifications "P" models are pressure only; "V" models are vacuum only

Model Number	Motor	Motor Type	RPM		HP	KW	Net Weight	
			60 Hz	50 Hz			lb	kg
*ROA-P201-AA	115-60-1	Shaded pole	1575	--	1/8	0.09	12.0	5.6
ROA-P201-BN	220/240-50-1	Shaded pole	--	1275	1/8	0.09	12.0	5.6
ROA-P108-DD	230/220-60/50-1	PSC	1575	1275	1/8	0.09	15.0	6.8
ROA-P108-EB	115/110-60/50-1	PSC	1575	1275	1/4	0.19	15.0	6.8
ROA-P208-DB	115/110-60/50-1	PSC (4 pole)	1575	1275	1/8	0.09	12.3	5.6
ROA-P208-FB	115/110-60/50-1	PSC (2 pole)	3000	2500	1/4	0.19	12.3	5.6
ROA-P209-DB	115/110-60/50-1	PSC	1575	1275	1/8	0.09	12.0	5.6
ROA-P201-JH	12V	DC	2100		1/8	0.09	10.0	4.5
ROA-P201-JK	24V	DC	2100		1/8	0.09	10.0	4.5
*ROA-V210-AA	115-60-1	Shaded pole	1575	--	1/8	0.09	12.3	5.6
†ROA-V210-BN	220/240-50-1	Shaded pole	--	1275	1/8	0.09	12.3	5.6
ROA-V210-JH	12V	DC	2100		1/8	0.09	10.0	4.5

- Oilless operation
- Motor mounted
- Rugged construction / low maintenance
- Low noise levels
- Muffler/filter AH190,
Capacitor AF873A (DB and DD motors)
Capacitor AF485A (FB motor) included

* Includes 10 foot cord, switch, and plug
† Includes 2 meter European color coded cord (no plug)

Product Performance

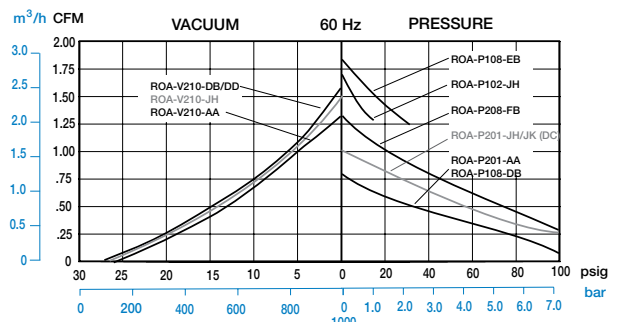
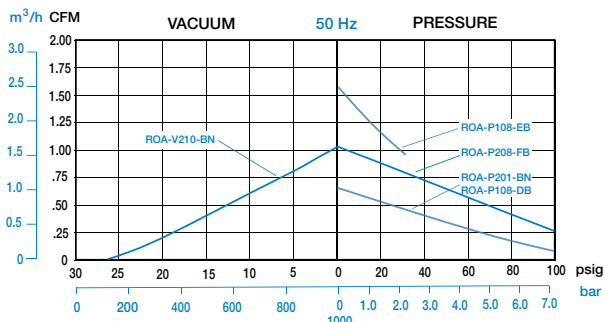



Shaded Pole Motor

100 psi max. pressure
25 inHg max. vacuum
0.8 CFM open flow (60 Hz)

Recommended Accessories

Repair kit K757

Includes

- Pressure gauge AF806
- Vacuum gauge AE136
- Pressure relief valve AF887
- Vacuum relief valve AA550C-V
- Hose barbs AG613
- Carrying handle AP523A
- Rubber feet AF584A

Product Dimensions (inches, mm)

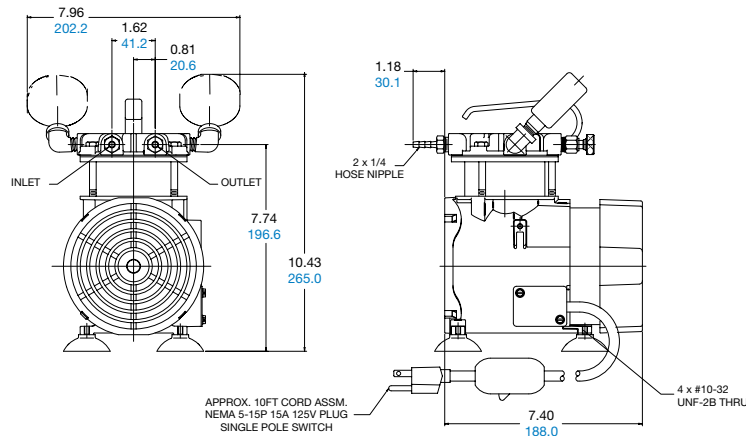

Product Specifications

Model Number	Motor	Motor Type	RPM		HP	KW	Net Weight	
			60 Hz	50 Hz			lb	kg
ROA-P104-AA	115-60-1	Shaded pole	1725	--	1/8		20	7.0
ROA-P104-BN	220/240-50-1	Shaded pole	--	1425	1/8	0.10	14	6.4

- Oilless operation
- Motor mounted
- Rugged construction / low maintenance
- CNL UL listed for use in Canada
- CE conforms to European standards

Product Performance

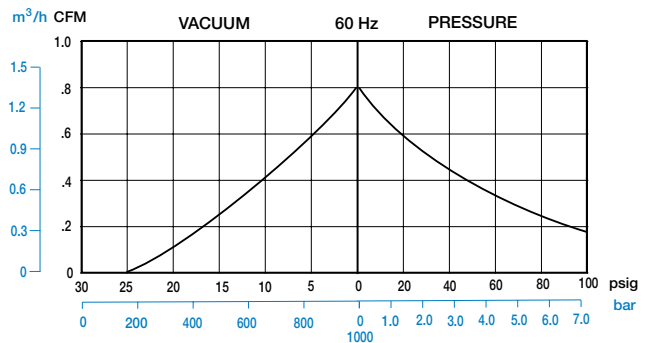
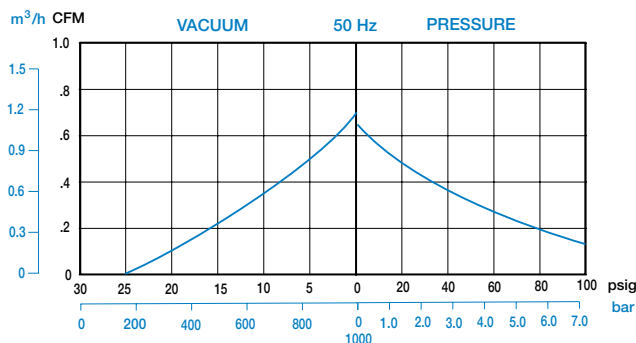



PSC 4 Pole Motor

100 psi max. pressure
1.55 CFM open flow (60 Hz)
27.5 inHg max. vacuum
2.7 CFM open flow (60 Hz)

PSC 4 Pole Motor Single Stg

29.0 inHg max. vacuum
1.5 CFM open flow (60 Hz)

PSC 2 Pole Motor

100 psi max. pressure
2.4 CFM open flow (60 Hz)

Recommended Accessories

Filter for vacuum only AA617G
Pressure gauge AF583
Vacuum gauge AA640
Pressure relief valve AF592S
Vacuum relief valve AA550C-V
(4) Rubber feet AF584A
(2) Repair kits K757

Product Dimensions (inches, mm)

EB/ED MOTORS

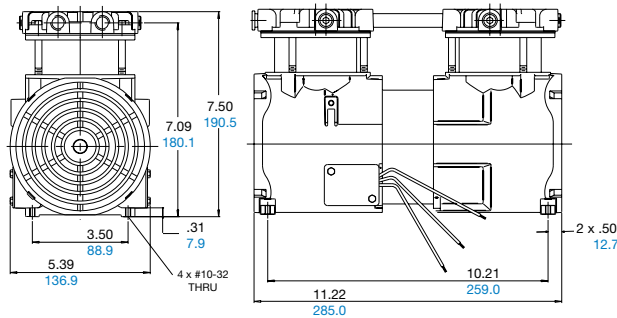

GB/GD MOTORS

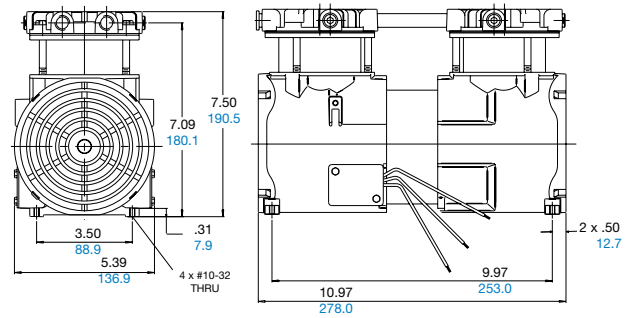

Product Specifications

Model Number	Motor	Motor Type	Staged/Parallel	RPM		HP	KW	Net Weight	
				60 Hz	50 Hz			lb	kg
RAA-P203-EB	115/110-60/50-1	PSC (4 pole)	--	1575	1275	1/4	0.19	19	8.6
RAA-P203-ED	230/220-60/50-1	PSC (4 pole)	--	1575	1275	1/4	0.19	19	8.6
RAA-P203-GB	115/110-60/50-1	PSC (2 pole)	--	3000	2500	1/4	0.19	19	8.6
RAA-P203-GD	230/220-60/50-1	PSC (2 pole)	--	3000	2500	1/4	0.19	19	8.6
RAA-V210-EB	115/110-60/50-1	PSC (4 pole)	Parallel	1575	1275	1/4	0.19	19	8.6
RAA-V211-EB	115/110-60/50-1	PSC (4 pole)	Staged	1575	1275	1/4	0.19	19	8.6
RAA-V210-ED	230/220-60/50-1	PSC (4 pole)	Parallel	1575	1275	1/4	0.19	19	8.6

- Oilless operation
- Motor mounted
- Rugged construction / low maintenance
- Low noise levels
- Muffler/filter AH190, unattached capacitor AF876 (EB motors) AF873A (EB motors) included

"P" models are pressure only; "V" models are vacuum only

Product Performance

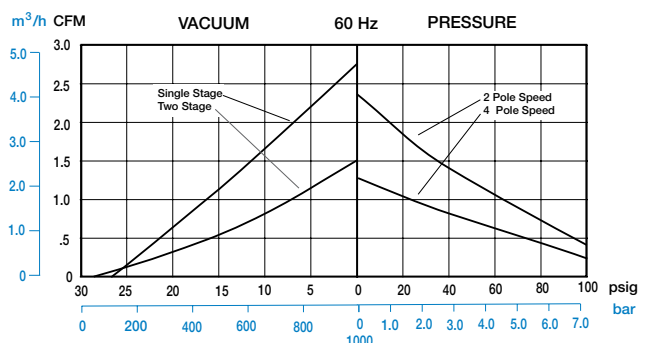
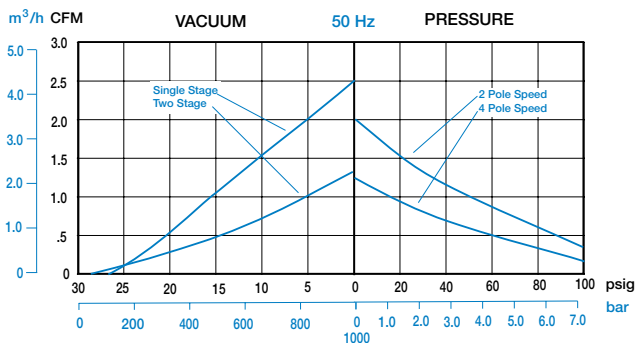



Models 71R142

100 psi max. pressure
2.0 CFM open flow (60 Hz)

Model 72R142

50 psi max. pressure
2.4 CFM open flow (60 Hz)

Recommended Accessories

In-line filter for vacuum units AA617G
Pressure gauge AF583
Vacuum gauge AA640
Pressure relief valve AF592S
Vacuum relief valve AA550C-V
(4) Rubber feet AB319A
Repair kit: 71R - K704
72R - K705

Product Dimensions (inches, mm)

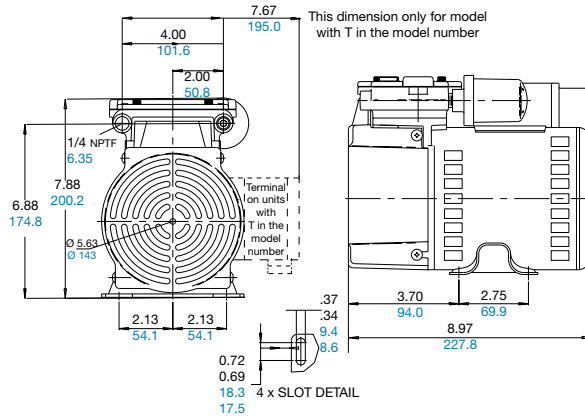

Product Specifications

Model Number	Motor	Motor Type	RPM		HP	KW	Net Weight	
			60 Hz	50 Hz			lb	kg
71R142-P001B-D300X	100/115-60/50-1	PSC (4 Pole)	1675	1400	1/3	0.25	14	6.4
71R142-P001B-D301X	200/240-50/60-1	PSC (4 Pole)	1675	1400	1/3	0.25	14	6.4
72R142-P0018-D300X	100/115-60/50-1	PSC (4 Pole)	1675	1400	1/3	0.25	17	7.7
72R142-P0018-D301X	200/240-50/60-1	PSC (4 Pole)	1675	1400	1/3	0.25	17	7.7

- Oilless operation
- All wetted aluminum parts treated for corrosion protection from moisture
- Rugged motor shell construction
- Muffler/filter B300F included

Product Performance

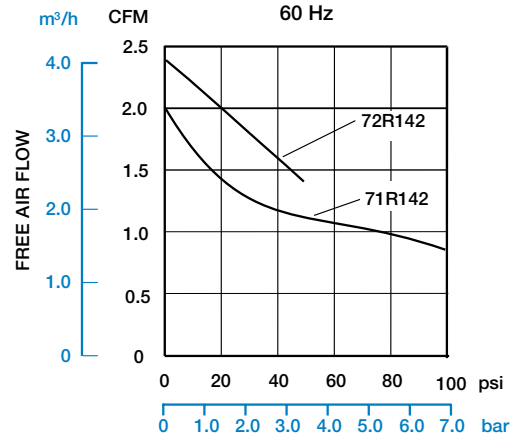
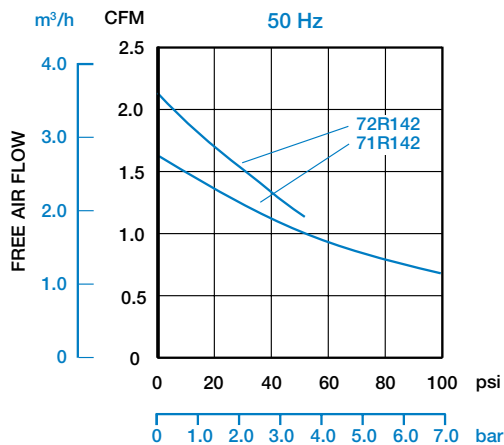



Model 71R545 Staged

175 psi max. pressure
2.0 CFM open flow (60 Hz)

Recommended Accessories

Repair kit K634

Includes

Capacitor AK385
Safety valve AS100J
Interstage filter AT441
(4) Rubber feet AF713A
Filter B300F not pictured,
shipped unattached

Product Dimensions (inches, mm)

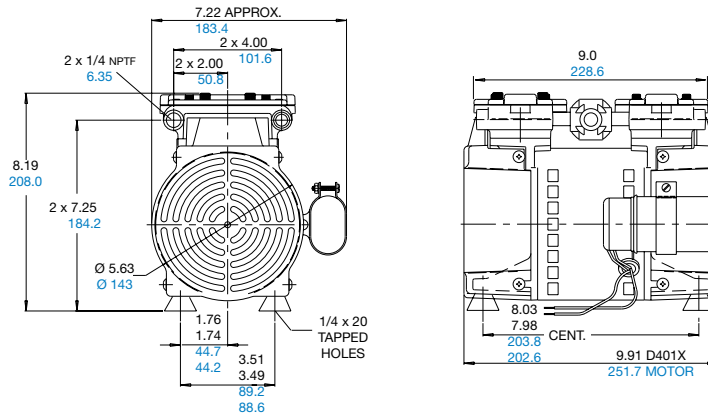

Product Specifications

Model Number	Motor	Motor Type	RPM		HP	KW	Net Weight	
			60 Hz	50 Hz			lb	kg
71R545-P315B-D401X	100/115-60-1	PSC (4 Pole)	1725	1425	1/2	0.37	15.6	7.09
71R545-P315B-D302CX	220/240-50-1	PSC (4 Pole)	--	1425	1/3	0.25	15.6	7.09

- Oilless operation
- All wetted aluminum parts treated for corrosion protection from moisture
- Rugged motor shell construction
- Muffler/filter B300F included

Product Performance

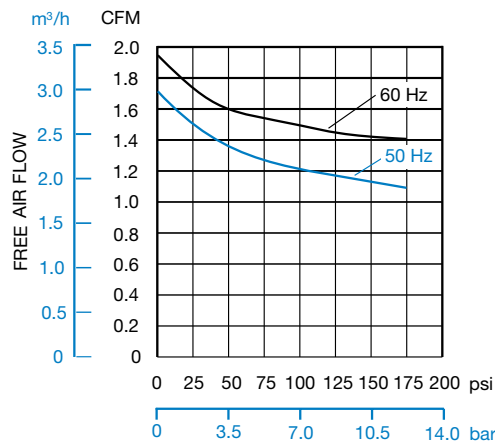



Model 71R642

100 psi max. pressure
3.5 CFM open flow (60 Hz)

Model 71R645/71R655

100 psi max. pressure
4.35 CFM open flow (60 Hz)

Models 71R645/71R655

100 15 psi max. pressure
5.5 CFM open flow (60 Hz)

Recommended Accessories

Relief valve AA600
Pressure gauge AA644B
Repair kit 71R K557
72R K558

Product Dimensions (inches, mm)

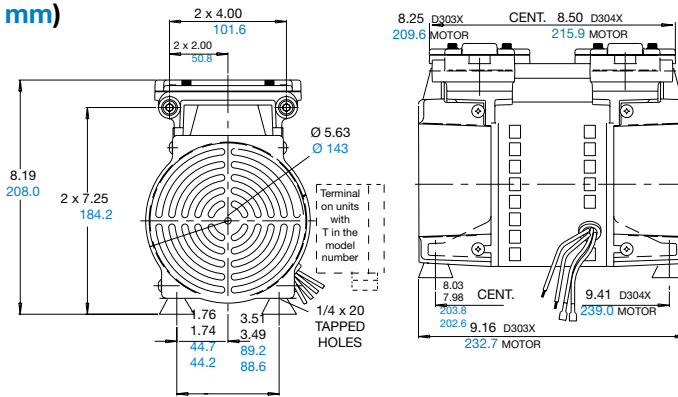

Product Specifications

Model Number	Motor	Motor Type	RPM		HP	KW	Net Weight	
			60 Hz	50 Hz			lb	kg
71R645-P112-D303X	115-60-1	PSC (4 pole)	1650	--	1/3	0.25	15.6	7.09
71R647-P10-C322X	220/240-50-1	PSC (4 pole)	--	1400	1/2	0.37	23.4	10.6
71R647-P10-C322	220/240-50-1	PSC (4 pole)	--	1450	1/3	0.25	19.8	9.0
*71R647-P10-C322TX	220/240-50-1	PSC (4 pole)	--	1450	1/3	0.25	23.4	10.6
71R655-P112-D304X	220/240-50-1	PSC (4 pole)	--	1425	1/3	0.25	16.0	7.27
72R645-P112-D303X	115-60-1	PSC (4 pole)	1650	--	1/3	0.25	15.6	7.09
72R655-P112-D304X	220/240-50-1	PSC (4 pole)	--	1425	1/3	0.25	16.0	7.27
71R647-P112-D401X	115-60-1	PSC (4 pole)	1650	--	1/2	0.37	15.6	7.09
71R642-P112-D501X	100/115-60-1 100-50-1	PSC (4 pole)	1650	--	3/4	0.37	15.6	7.09
71R645-P112D-D402CX	220/230-60-1 220/240-50-1	PSC (4 pole)	1650	--	1/2	0.37	15.6	7.09
71R647-P112U-D500CX	115-60-1	PSC (4 pole)	1650	--	3/4	0.56	15.6	7.09

* Unit with terminal box

- Oilless operation
- All wetted aluminum parts treated for corrosion protection from moisture
- Rugged motor shell construction
- Includes
Dry-cell capacitor AT250 (D303X motor),
AT251 (D304X motor)-not pictured, shipped unattached
(4) rubber feet AF713A

Product Performance

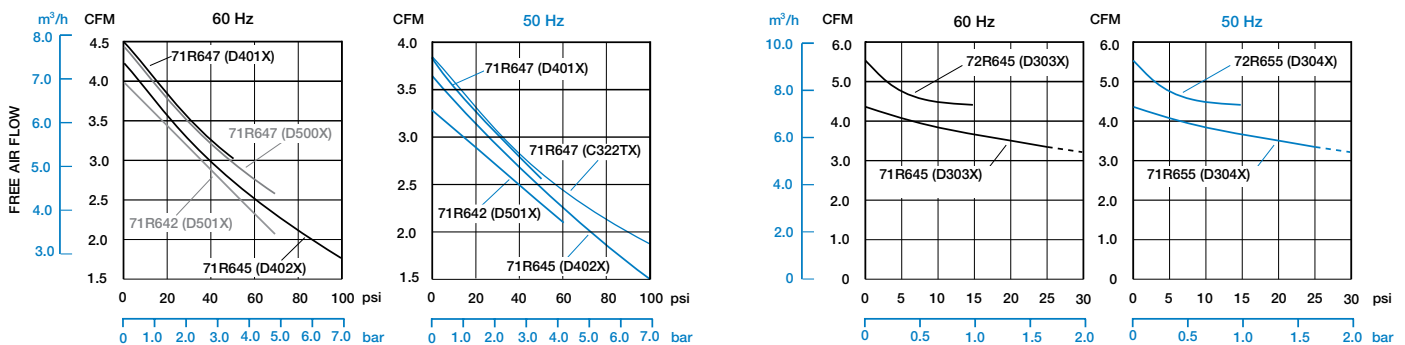



Models 71R645/71R655

28 inHg max. vacuum
4.5 CFM open flow (60 Hz)

Models 72R547/72R555 Staged

29 inHg max. vacuum
2.6 CFM open flow (60 Hz)

Models 72R645/72R655

28 inHg max. vacuum
5.5 CFM open flow (60 Hz)

Product Dimensions (inches, mm)

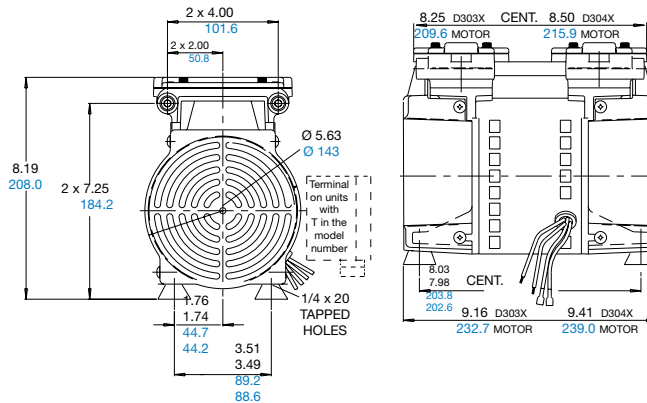

Product Specifications

Model Number	Motor	Motor Type	Parallel/ Staged	RPM	60 Hz	50 Hz	HP	KW	Net Weight lb	kg
71R645-V114-D303X	115-60-1	PSC (4 pole)	Parallel	1650	--	1/3	0.25	15.6	7.09	
71R655-V10-C222X	220/240-50-1	Shaded Pole	Parallel	--	1450	1/3	0.25	16.0	7.27	
*71R655-V10-C222TX	220/240-50-1	Shaded Pole	Parallel	--	1450	1/3	0.25	16.0	7.27	
71R655-V114-D304X	220/240-50-1	PSC (4 pole)	Parallel	--	1425	1/3	0.25	16.0	7.27	
72R547-V116-D303X	115-60-1	PSC (4 pole)	Staged	1650	--	1/3	0.25	15.6	7.09	
72R555-V10-C222X	220/240-50-1	Shaded Pole	Staged	--	1450	1/3	0.25	19.8	9.0	
72R555-V10-C222TX	220/240-50-1	Shaded Pole	Staged	--	1450	1/3	0.25	19.8	9.0	
72R555-V116B-D204X	220/240-50-1	PSC (4 pole)	Staged	--	1425	1/3	0.25	16.0	7.27	
72R645-V114-D303X	115-60-1	PSC (4 pole)	Parallel	1650	--	1/3	0.25	15.6	7.09	
72R655-V10-C222X	220/240-50-1	Shaded Pole	Parallel	--	1450	1/3	0.25	21.8	9.9	
72R655-V10-C222TX	220/240-50-1	Shaded Pole	Parallel	--	1450	1/3	0.25	21.8	9.9	
72R655-V114-D304X	220/240-50-1	PSC (4 pole)	Parallel	--	1425	1/3	0.25	16.0	7.27	

* All model numbers with T have a terminal box attached

- Oilless operation
- All wetted aluminum parts treated for corrosion protection from moisture
- Rugged motor shell construction
- Includes
 - Dry-cell capacitor AT250 (D303X motor), AT251 (D304X motor)-not pictured, shipped unattached
 - (4) rubber feet AF713A

Product Performance

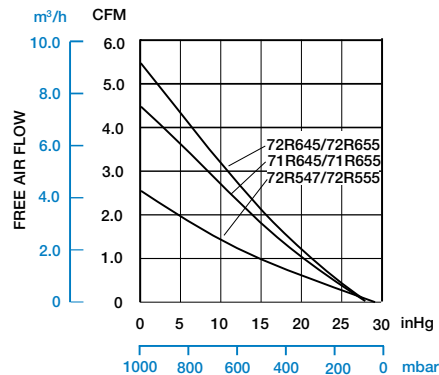



Model 74R130

100 psi max. pressure
1.50 CFM open flow (60 Hz)

100 psi max. pressure
1.25 CFM open flow (50 Hz)

Recommended Accessories

Pressure gauge AF583
Pressure relief valve AF592S
(4) Rubber feet AF713A
Repair kit K806

Product Dimensions (inches, mm)

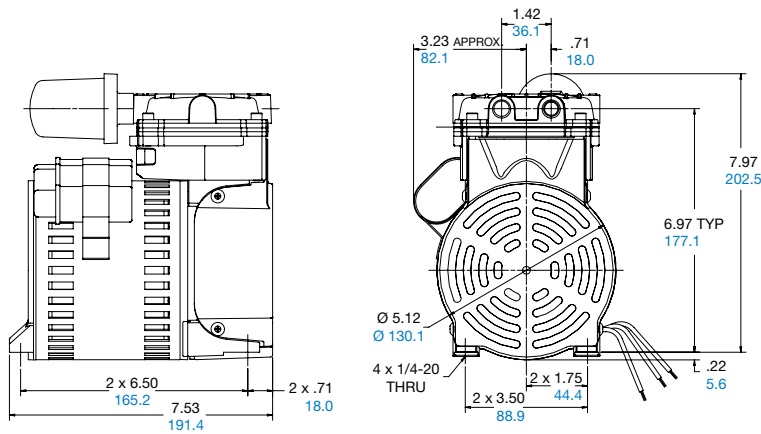

Product Specifications

Model Number	Motor	RPM		HP	KW	Net Weight	
		60 Hz	50 Hz			lb	kg
74R130-P101-H200X	100-115-60/50-1	1625	1375	1/4	0.19	14.2	6.4
74R130-P101-H200X	220-240/230-50/60-1	1625	1375	1/4	0.19	14.3	6.5
74R130-P101-H203X	115/230-60-1 :220/240-50-1	1625	1375	1/4	0.19	14.3	6.5
**74R130-P101D-H203X	115/230-60-1 :220/240-50-1	1625	1375	1/4	0.19	14.3	6.5
*74R130-P114-H200X	100-115-60/50-1	1625	1375	1/4	0.19	14.2	6.4
*74R130-P114-H201X	220-240/230-50/60-1	1625	1375	1/4	0.19	14.3	6.5

* Has M5 foot mount

** Biased valve

- Oilless operation
- All wetted aluminum parts treated for corrosion protection from moisture
- Rugged motor shell construction
- Filter B300A included
- H200 and H201 motors have 3 pigtail wire arrangement
- H203 has 6 pigtail wire arrangement

Product Performance

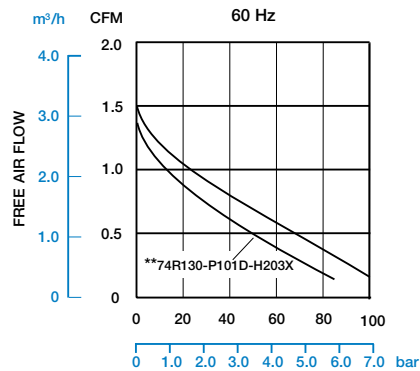
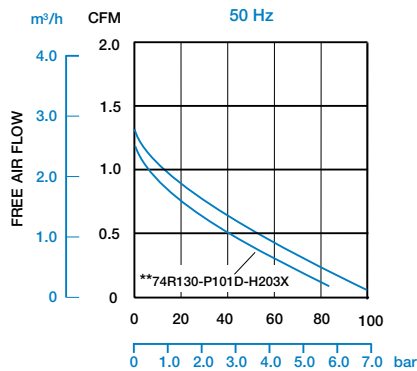



MODEL 75R647

20 psi max. pressure,
27 inHg max. vacuum
5.1 CFM open flow (60 Hz)

MODEL 75R645

30 psi max. pressure
4.9 CFM open flow (60 Hz)

MODEL 75R640

40 psi max. pressure,
4.45 CFM open flow (60 Hz)

MODEL 75R635

30 psi max. pressure
4.05 CFM open flow (60 Hz)

Recommended Accessories

- Pressure gauge AA644B
- Vacuum gauge AA640
- Pressure relief valve AF592S
- Vacuum relief valve AA204
- (4) Rubber feet AF713A
- Repair kit K797

Product Dimensions (inches, mm)

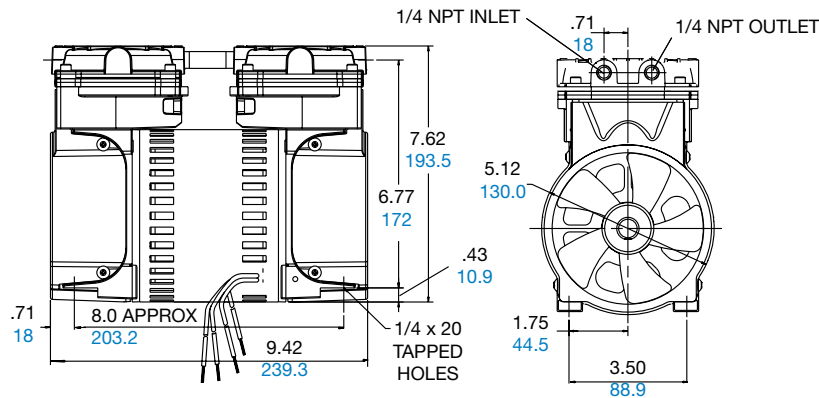

Product Specifications

Model Number	Motor	Motor Type	RPM		HP	KW	Net Weight		Capacitor
			60 Hz	50 Hz			lb	kg	
75R635-P101-H301X	100-115-60/50-1	PSC	1625	1375	1/3	0.25	17.1	7.8	AT546A
75R640-P101-H301X	115-60-1	PSC	1625	--	1/3	0.25	17.1	7.8	AT546A
75R645-P101-H301X	115-60-1	PSC	1625	--	1/3	0.25	17.1	7.8	AT367
75R647-P101-H301X	115-60-1	PSC	1625	--	1/3	0.25	17.5	7.9	AT251
*75R647-V101-H301X	115-60-1	PSC	1625	--	1/3	0.25	17.5	7.9	AT251
75R645-P101-H302CX	220-240/230-50/60-1	PSC	1625	1375	1/3	0.25	17.6	8.0	AT250
75R647-P101-H302CX	220-240/230-50/60-1	PSC	1625	1375	1/3	0.25	18.0	8.2	AT251
75R647-P101A-H311CX	115-60-1	PSC	1625	--	1/3	0.25	18.0	8.2	AT251

- Oilless operation
- All wetted aluminum parts treated for corrosion protection from moisture
- Rugged motor shell construction
- Filter/muffler included

* Vacuum only model

Product Performance

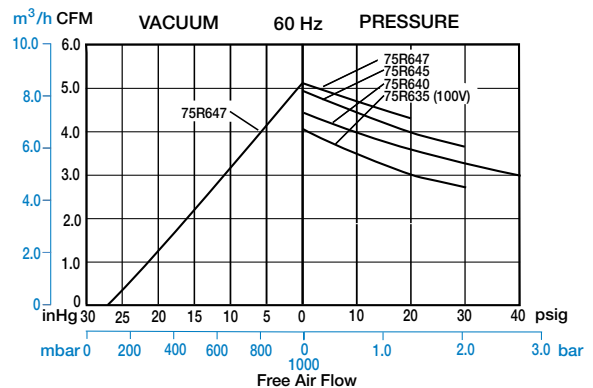
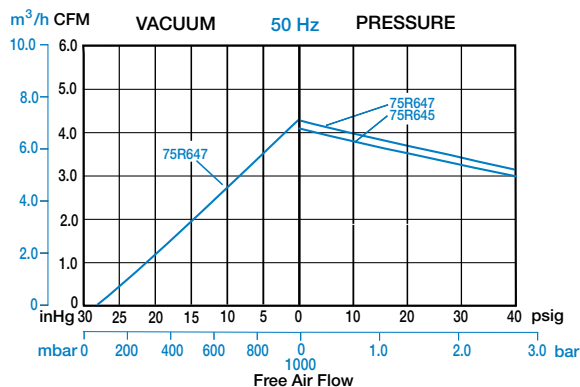



Model 75R135
27 inHg max. vacuum
1.9 CFM open flow (60 Hz)

Recommended Accessories

- Vacuum gauge AA640
- Vacuum relief valve AA204
- (4) Rubber feet AF713A
- Repair kit K806

Product Dimensions (inches, mm)

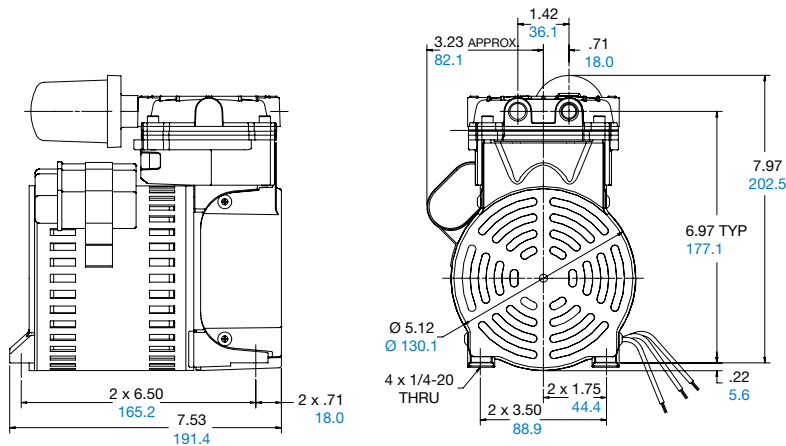

Product Specifications

Model Number	Motor	Motor Type	RPM		HP	KW	Net Weight	
			60 Hz	50 Hz			lb	kg
75R135-V102-H200X	100/100-115-50/60-1	PSC	1625	1375	1/4	0.19	14.3	6.5
75R135-V103-H203X	115/230-60-220-240-50	PSC	1625	1375	1/4	0.19	14.3	6.5

- Oilless operation
- All wetted aluminum parts treated for corrosion protection from moisture
- Rugged motor shell construction
- Filter/muffler included

Product Performance

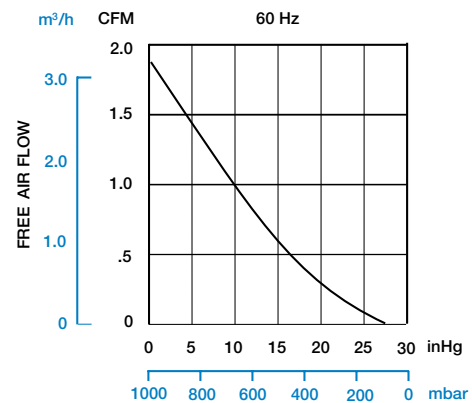
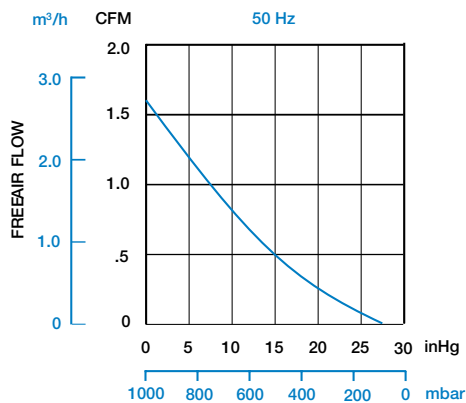



Model 81R640

100 psi max. pressure
3.7 CFM open flow (60 Hz)

100 psi max. pressure
3.0 CFM open flow (50 Hz)

Recommended Accessories

Pressure gauge AA806

Safety valve AP202

Filter B300A

Capacitors AT251 dry or AJ594 wet

Repair kit K934

Product Dimensions (inches, mm)

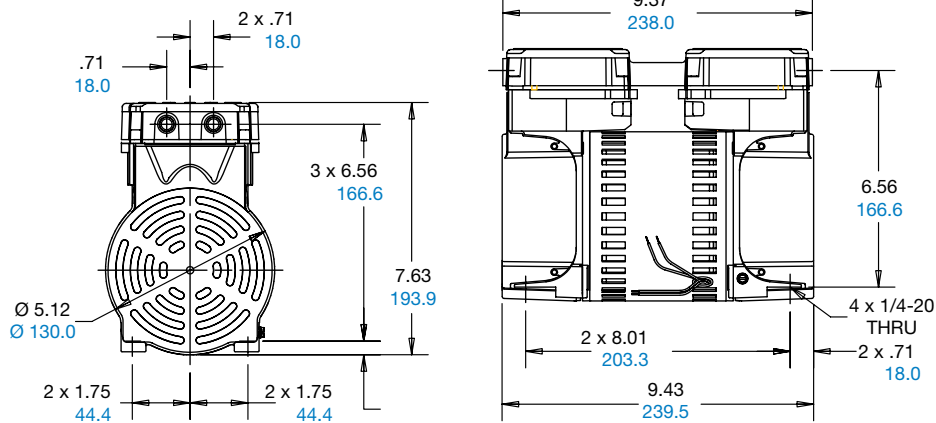

Product Specifications

Model Number	Motor	Motor Type	RPM		HP	KW	Net Weight	
			60 Hz	50 Hz			lb	kg
81R640-P101-H311CX	115-60-1	PSC	1725	--	1/3	0.25	17.1	7.8
81R640-P101-H302CX	220-240-50-1	PSC	--	1450	1/3	0.25	17.1	8.0

- Oilless operation
- All wetted aluminum parts treated for corrosion protection from moisture
- Rugged motor shell construction

Product Performance

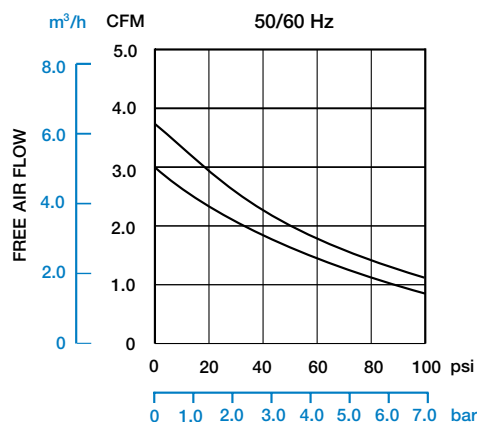



MODEL 82R637 Series

30 psi max. pressure
4.3 CFM open flow (60 Hz)

30 psi max. pressure
3.8 CFM open flow (BLDC)

MODEL 82R637 Series

30 psi max. pressure
4.7 CFM open flow (60 Hz)

30 psi max. pressure
4.1 CFM open flow (50 Hz)

MODEL 82R642 Series

100 psi max. pressure
4.4 CFM open flow (60 Hz)

100 psi max. pressure
3.2 CFM open flow (50 Hz)

MODEL 82R645 Series

30 psi max. pressure
4.9 CFM open flow (60 Hz)

30 psi max. pressure
4.4 CFM open flow (50 Hz)

Product Dimensions (inches, mm)

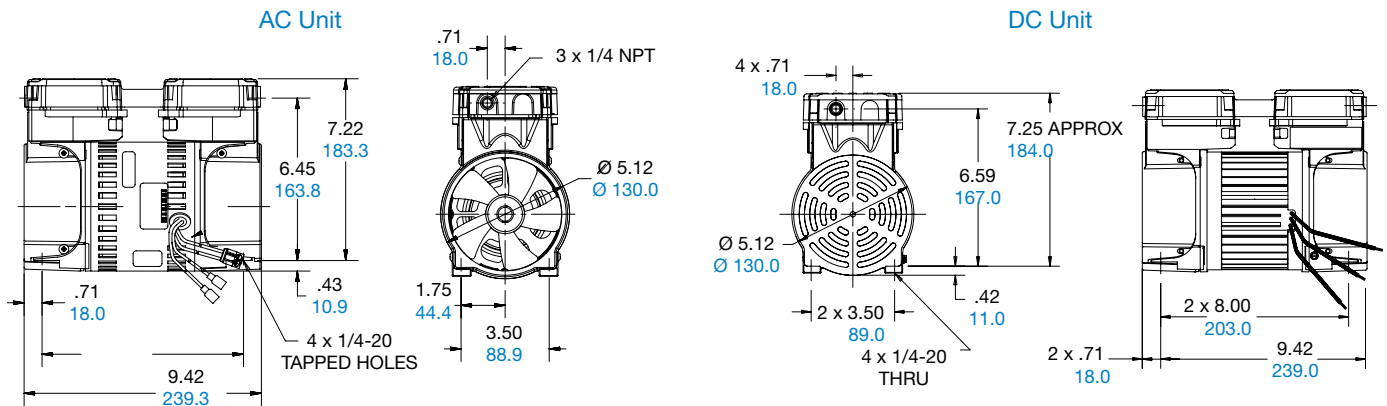

Product Specifications

Model Number	Motor	Motor Type	RPM		HP	KW	Net Weight	
			60 Hz	50 Hz			lb	kg
82R637-P135-H311CX	115-60-1	PSC	1725	--	1/3	0.25	17.1	7.8
82R637-P150-H314X	24V	PM		2000	1/3	0.25	17.9	8.1
*82R642-P112-H302CX	230-60-1	PSC	1725	1425	1/3	0.25	17.1	7.8
	220/240-50-1	PSC	1725	1425	1/3	0.25	17.1	7.8
82R642-P136-H302CX	230-60-1	PSC	1725	1425	1/3	0.25	17.1	7.8
	220/240-50-1	PSC	1725	1425	1/3	0.25	17.1	7.8
82R645-P107-H304X	110-115/230-60-1	PSC	1725	1425	1/3	0.25	17.1	7.8
	10/220-50-1	PSC	1725	1425	1/3	0.25	17.1	7.8
82R645-P135-H302CX	230-60-1	PSC	1725	1425	1/3	0.25	17.1	7.8
	220/240-50-1	PSC	1725	1425	1/3	0.25	17.1	7.8

* Units will start against 50 psi back pressure

- Oilless operation
- All wetted aluminum parts treated for corrosion protection from moisture
- Rugged motor shell construction
- Recommended Accessories
 - Pressure gauge AF583
 - Relief valve AP202
 - Filter B300A
 - Repair kit K797A
 - Capacitors: AT251 (82R637-P135-H311CX)
 - AT251B 82R642-P112-H302CX
 - 82R642-P136-H302CX
 - 82R645-P135-H302CX
 - AT385 (82R645-P107-H304X, shipped with unit)

Product Performance

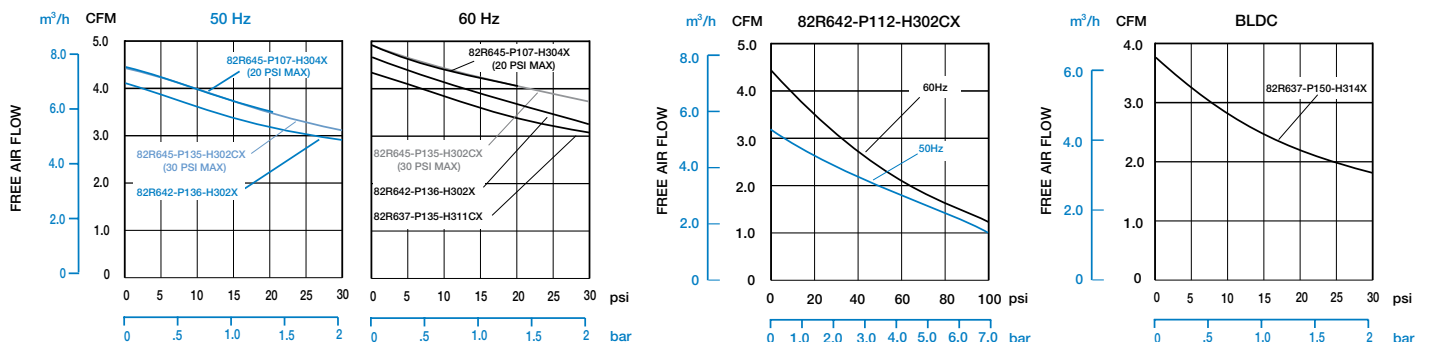

Notes:

A series of 25 horizontal lines for writing notes.



Gast Manufacturing, Inc.

A Unit of IDEX Corporation
Post Office Box 97
2300 M-139 Highway
Benton Harbor, Michigan 49023-0097
Phone 269-926-6171
Fax 269-925-8288
www.gastmfg.com

Gast Hong Kong

Room 6, 9/F, New Commerce Centre
19 On Sum Street, Shatin
Hong Kong
Phone 852-2690-1008
Fax 852-2690-1012

Gast Group Ltd.

A Unit of IDEX Corporation
Unit 11, The I O Centre
Nash Road
Redditch, B98 7AS
United Kingdom
Phone +44 (0)1527-504040
Fax +44 (0)1527-525262